

PELLETIZING & PULVERIZING SYSTEMS >

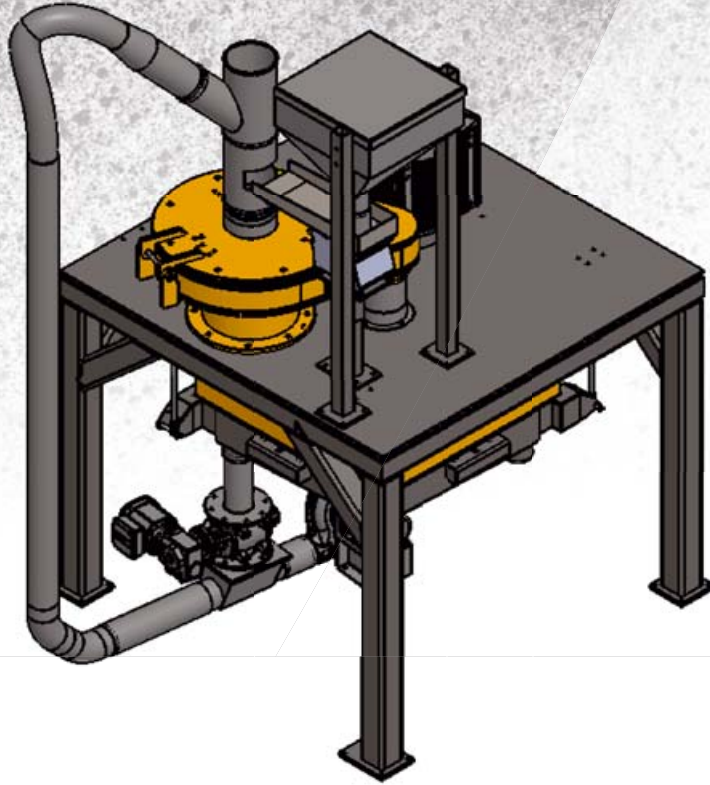

Pulverizer REX Powder

Xtremely quick return
on investment

 **REDUCTION**

The unit is manufactured for both ambient and cryogenic operation with use of the proper attachments. This versatile pulverizer can service the smaller markets with a quick ROI. Almost anything can be trialed on this unit – from engineered resins, rubber, adhesives, pharmaceuticals as well as food grades. The REX Powder will give you a range of rates from 50KGs per hour to 200KGS per hour.

Advantages

- High energy efficiency
- Small footprint
- Turnkey (Plug and Play)
- Standard Disposable Discs are used
- Standard Screen size are used
- **NEW:** Spring actuated gap adjustment
- **NEW:** Air handling system (patented)

Pulverizer REX Powder

Xtremely quick return on investment

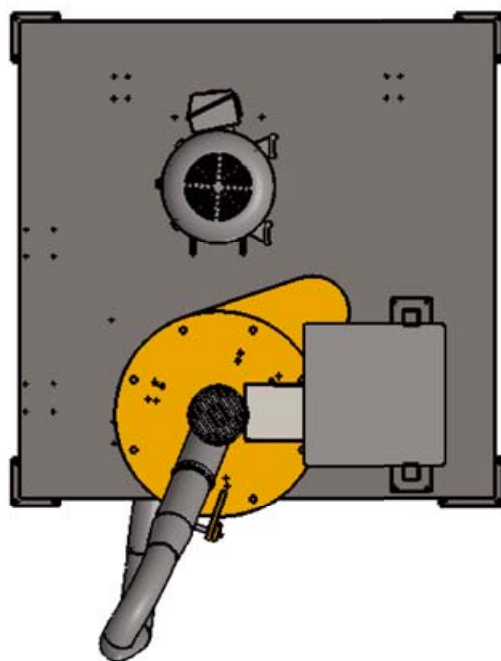
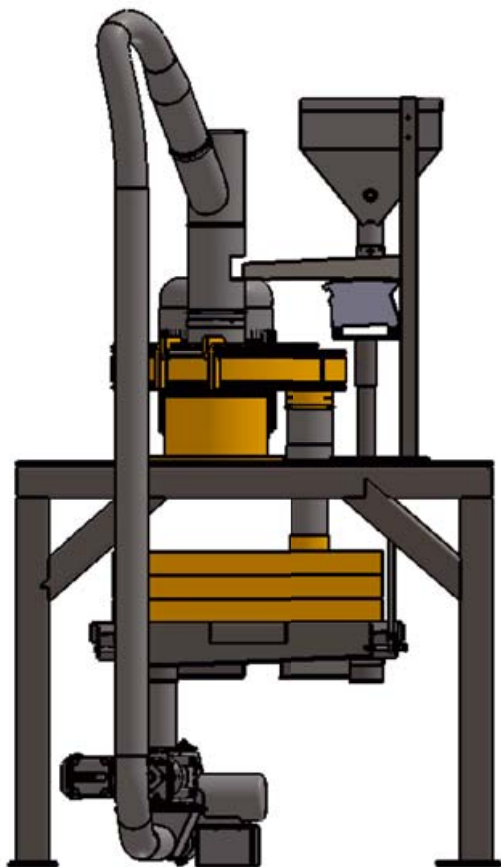

Technical Data:		REX Powder
Material:		LDPE, HDPE, PVC, ABS, ... ¹⁾
Feed Size:		≤ 10.0 mm
Final Fineness:		e.g. 500 µm
Output:		up to 180 kg/h
Discs:	No. / Diameter	2 / 432 mm
Main Drive:		22 kW
Screens	Number / Area	3 / 1.5 m ²
	Mesh	e.g. 35
Controls:	Siemens	HMI
Dimensions:	L x W x H	approx. 1,200 x 800 x 2,400 mm

1) further materials upon request

